



# Grandeye Halocam IPM

## IP67-rated 360° Minidome IP Camera

---

### Product Features

- 5 megapixel image sensor
- 360° field of view
- Four de-warped ePTZ virtual cameras
- 10x optical-equivalent zoom
- Retrospective scene analysis with ePTZ\*
- On-board video analytics
- Multi-target tracking
- Multi-view video streams
- Video streams in multiple resolutions from QQVGA (160x120) to 2144x1944
- 10fps typical
- IEEE802.3af class 2 Power-over-Ethernet
- MJPEG stream with multiple quality levels
- Multilevel password protection
- Minimum illumination 0.5 lux
- FTP, HTTP, TCP, UDP, TELNET, ARP, ICMP, SMTP, DHCP, RARP, DNS and NTP support
- Vandal resistant enclosure



*\*When used with a compatible recorder*

The Grandeye IPM is a 360° minidome IP camera with a 5 megapixel sensor and no moving parts. The unit is designed for applications where ingress protection to IP67 is a requirement and it fully supports IEEE802.3af Class 2 Power over Ethernet for installation convenience.

The IPM provides total situational awareness over a 360° field of view with the ability to generate a number of video streams at a choice of resolutions, thereby optimising bandwidth and storage utilisation within a system. Grandeye's powerful, patented in-camera processing provides 4 de-warped virtual cameras (VCAMs) which offer independent pan, tilt and zoom operation, as well as panoramas and fisheye images.

The IPM is based on award-winning technology and includes in-camera video analytics, which enable motion detection and tracking, with up to four targets being tracked simultaneously using VCAMs.

Grandeye's comprehensive SDK enables digital recording systems manufacturers to integrate directly to the camera and offer retrospective pan, tilt and zoom during playback.

---

Grandeye Ltd, 6 Huxley Road, Guildford GU2 7RE UK  
Tel +44 (0)1483 302312 Fax +44 (0)1483 300141 Email: [salesinfo@grandeye.com](mailto:salesinfo@grandeye.com) Web: [www.grandeye.com](http://www.grandeye.com)

Grandeye Limited reserved the right to change specifications without notice in the interest of product development. E&OE.  
Halocam is a registered trademark of Grandeye Limited.  
© Copyright 2008 Grandeye Limited. All rights reserved.



## TECHNICAL SPECIFICATIONS

<b>Model</b>	
GG017	360° minidome IP camera with a 5 megapixel sensor and no moving parts
<b>General</b>	
Image sensor	5 megapixel (2592x1944)
Angle of view	180° circle (full hemisphere)
Minimum illumination	0.5 lux
Frame rate	10fps typical
Zoom	10x optical equivalent
Video analytics	10 polygonal regions of interest; Motion detect; Motion track; Configurable response; Multi-target simultaneous tracking; Adjustable tracking characteristics
ePTZ	Immediate response
Presets	10 presets
Image pipeline	IMTERA 2™ 3-D visual image pipeline unit; 12-bit
External input	1 contact input
External output	1 momentary or transparent
Security	Multi-level access with configurable passwords; IP address filtering; HTTPS encryption
Users	20 simultaneous users
Event management	Triggered by motion, external input or HTTP event. Result configurable: PTZ tracking; external output; FTP/SFTP upload; HTTP notification
Privacy	10 polygonal, configurable privacy regions
<b>Electrical</b>	
Ports	RJ45 for 100Base-TX; 2.1mm DC Input jack; 3-pin 1.5mm Phoenix for external I/O
Network cable type	CAT5 or better for 100Base-TX
Power input	5V DC or PoE IEEE802.3af Class 2
Power consumption	5W max
<b>Mechanical</b>	
Camera mount	Use 4 x M4.5 (No8) screw, as supplied, to secure base of camera to surface
Weight	1.2kg (2.64lbs)
Enclosure	All-aluminium dome enclosure with polycarbonate dome cover
<b>Environmental</b>	
Operating temperature range	0-60°C (32-140°F) in free air flow
Storage temperature	-10 to +60°C (14 to 140°F)
Ingress protection rating	IP67
<b>Video</b>	
Video codec	Motion JPEG
Compression level	95 levels of compression adjustment
Video stream resolution	Virtual cameras at: QQVGA; QVGA; VGA; XGA Panoramas at: 640x208 Fisheyes at: VGA; 1024x1024; 2144x1944
Image settings	Exposure mode; compression level; brightness; contrast; white balance;
Web browser compatibility	Internet Explorer (with ActiveX plug-in, supplied); Mozilla Firefox V2.x
<b>Certifications/Ratings/Patents</b>	
Patents	10 patents; 15 pending patents; 20 licensed patents
Approvals	IP67; IEEE802.3af Class 2; <b>EMC:</b> (CISPR Class B) FCC, CE, ICES-003 <b>SAFETY:</b> UL60950 (pending)

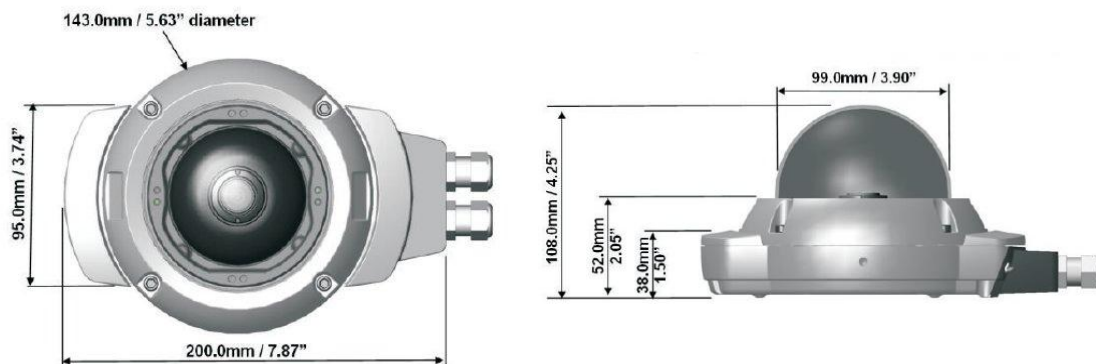

Grandeye Ltd, 6 Huxley Road, Guildford GU2 7RE UK  
 Tel +44 (0)1483 302312 Fax +44 (0)1483 300141 Email: salesinfo@grandeye.com Web: www.grandeye.com

Grandeye Limited reserved the right to change specifications without notice in the interest of product development. E&OE.  
 Halocam is a registered trademark of Grandeye Limited.  
 © Copyright 2008 Grandeye Limited. All rights reserved.